



## MHYC SSORC SUPER 12 REGATTA 26<sup>TH</sup> & 27<sup>TH</sup> NOVEMBER 2016

### SAILING INSTRUCTIONS SAT 26 NOVEMBER

#### **1 RULES**

- 1.1 The regatta shall be governed by the "rules" as defined in the 2013 - 2016 Racing Rules of Sailing (RRS), Yachting Australia Special Regulations Part 1 Category 7 except as any of these are changed by the sailing instructions.
- 1.2 RRS 44.2 is amended in that only one turn, including one tack and one gybe, is required except for infringements that occur within two boat lengths of a rounding mark
- 1.3 The race committee may carry out random checks for compliance of Rules as noted in 1.1 at any time during the regatta.

#### **2 REGISTRATION AND WEIGH-IN**

- 2.1 Entry is online through Top Yacht,.No registration or weigh in is required for this regatta.

#### **3 NOTICES TO COMPETITORS**

- 3.1 The official notice board is a notice board bearing that name outside the MHYC Sailing Office
- 3.2 VHF channel 72 shall be used as the Race Communications channel.
- 3.3 The Race Committee may broadcast race information before and during each race. Any such communication shall not be deemed as outside help. This Alters RRS 41.

#### **4 SIGNALS MADE ASHORE**

- 4.1 Signals made ashore will be displayed on the flagstaff, located in front of the clubhouse.
- 4.2 Code flag "AP" with two sound signals (one when lowered) when displayed ashore means "Races not started are postponed". The Warning Signal shall not be made less than 30 minutes after the "AP" is lowered ashore. This Alters RRS Race Signals

#### **5. CHANGES TO SAILING INSTRUCTIONS**

- 5.1 Changes to the sailing instructions made ashore shall be posted before 1000 hrs on the day they shall take effect.
- 5.2 Changes to the Sailing Instructions made afloat shall be indicated by the display of Code Flag 3<sup>rd</sup> Substitute accompanied by two sound signals. The change may be communicated either orally or in writing.

#### **6. SCHEDULE OF RACING**

- 6.1 The regatta shall consist of a maximum of six (6) races.

Date	Event	Warning Signal
Saturday 26 <sup>th</sup> Nov	Up to 4 W/L races	1055hrs
Sunday 27 <sup>th</sup> Nov.	See separate Sailing Instructions	1155hrs
Sunday 27 <sup>th</sup> Nov	Presentation of Prizes	<i>Asap after racing</i>

## 7 RACING AREA

8.1 The Racing Area will be on the waters of Sydney Harbour and will be indicated by a Notice posted by 1000 hrs on the Official Notice Board each day.

## 9 MARKS

9.1 Mark 1 and the Gate marks will be orange buoys.

9.2 Mark 1a will be a yellow buoy

9.3 The start / finish mark will be a yellow buoy.

9.4 The change mark(s) as per SI 12, will be an orange buoy with a black band.

## 9. THE COURSE

9.1 The courses shall be windward / leeward.

9.2 A board displaying the course and approximate compass bearing from the mid-point of the starting line to Mark 1 shall be displayed by the Race Committee Boat.

9.3 Mark 1 shall be laid to windward of the start line. Mark 1a shall be laid to port of Mark 1.

9.4 The Gate may be laid approximately 50 metres to windward of the starting line. (Note: The Gate may be laid after the starting signal)

9.5 Yachts shall sail between the Gate marks from the direction of the previous mark and round either Gate mark. If only one Gate mark is set, the mark shall be rounded to port.

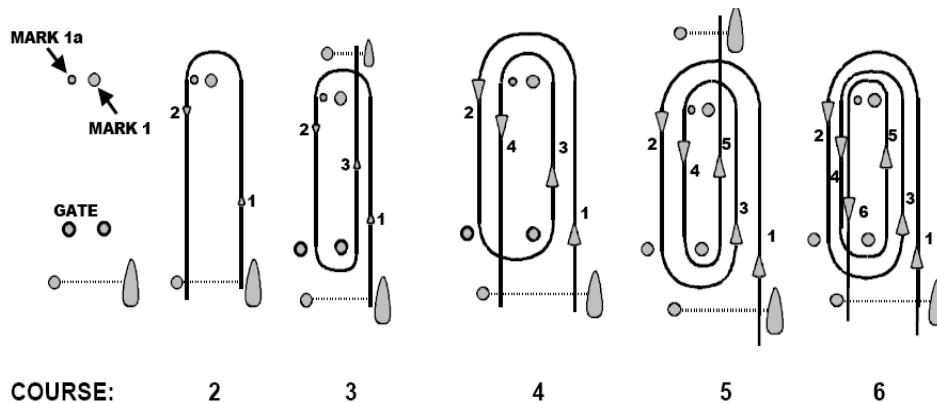

COURSE SIGNAL	COURSE CONFIGURATION All Marks rounded to PORT
2	Start - 1 - 1a - Finish (Downwind)
3	Start - 1 - 1a - Gate - Finish (Upwind)
4	Start - 1 - 1a - Gate - 1 - 1a - Finish (Downwind)
5	Start - 1 - 1a - Gate - 1 - 1a - Gate - Finish (Upwind)
6	Start - 1 - 1a - Gate - 1 - 1a - Gate - 1 - 1a - Finish (Downwind)

## 10 THE START

10.1 The Class Flag shall be International Code Flag "F".

10.2 Shall be between the Start / Finish Mark and the flagstaff displaying an orange flag on the Race Signal Vessel.

## **11 RECALLS**

11.1 In addition to RRS 29, the Race Committee MAY call yachts on channel 72.

## **12 CHANGING AND SHORTENING THE COURSE**

12.1 When changing the position of the next mark, the race committee shall lay a change mark(s). Any subsequent marks may be relocated to maintain the original course configuration. Further changes of that mark shall revert to the original mark(s).

## **13 FINISH LINE**

13.1 Shall be between the Start / Finish mark and the flagstaff displaying an orange flag on the Race Signal Vessel. The Start / Finish mark may be relocated closer to the Race Signal Vessel after the start.

## **14 TIME LIMIT**

14.1 The time limit for all races shall be 2 hours from the start, or within twenty five minutes of the first boat to finish, whichever is the earliest.

14.2 Yachts not finishing within the time limit shall be scored points equal to the number of boats finishing within the time limit plus two points, but no more points than the number of starters. This changes RRS 35, A4.2 and A5.

## **15 PROTESTS**

15.1 Submission of Protests:

Protests in accordance with RRS 61 shall be delivered to the MHYC Sailing Office within 1.5 hours after the finish time of the last boat. (in the last race of the day when multiple races are conducted).

15.2 Hearing of Protests:

Protests may be heard in approximately the order of receipt. In accordance with RRS 63.2, a notice of Hearing will be posted on the official notice board within ten minutes after the end of the protest time limit.

15.3 Reopening a Hearing:

RRS 66 is changed by adding: "On the last day of racing, a party to the hearing may ask for a reopening no later than half an hour after being informed of the decision."

15.4 In accordance with RRS 64.1(a) the protest committee may make any determination it decides is equitable for the fleet.

## **16 ARBITRATION**

16.1 At the option of the protest committee a short arbitration hearing may be heard prior to a protest hearing (affecting Rule 63). After the written protest form is properly lodged, one representative from each boat shall meet with the arbitrator, no witnesses shall be allowed. Protests not resolved by arbitration shall be lodged with the Protest Committee.

16.2 Boats that accept fault at an arbitration hearing shall be penalised by having her race score increased by a 40% scoring penalty calculated as stated in rule 44.3(c) but not more than a DSQ. All other boats scores shall remain the same. Once accepted by all parties, this decision is not subject to reopening or appeal and the protest shall be withdrawn. This alters RRS 60.1, 62 and 66.

16.3 The arbitrator may be a member of any subsequent Protest Committee.

## **17 SCORING**

17.1 The MHYC Super 12 Regatta will consist of a maximum of six (6) races. The minimum races to constitute a series will be two (2).

17.2 The Low Point scoring system, Appendix A of the RRS shall apply except all races shall count for total points.

## **18 PRIZES AND TROPHIES**

18.1 Prizes shall be awarded to each yacht placing first, second and third in the regatta.